



Fabrication Submittal Package – MJ Anchor Couplings

Standard Submittal Package

Kenneth J. Kempf

1/10/2018



4309 N. 26th Street, Omaha NE. 68111
PH: (402) 451-0674 * FAX: (402) 457-6710

Distributor: _____ Date: _____
Address: _____ Contractor: _____
City: _____ State: _____ Zip Code: _____
Job Name: _____

RE: MJ Anchor Couplings

Dear Valued Customer,

This letter is intended as certification that the pipe supplied by BLUE PATRIOT FAB is manufactured in accordance with ANSI/AWWA C150/A21.15-94.

The Ductile Iron Pipe fabricated by BLUE PATRIOT FAB is AMERICAN Ductile Iron Pipe, Class 53 or greater, and is manufactured in accordance with and meets or exceeds all applicable requirements of AWWA C151/A21.51-96

The cement lining is in accordance with ANSI/AWWA C104/A21.4-95. MJ Glands are in accordance with ANSI/AWWA C111/A21.11. All materials incorporated into these products are NSF 61 approved and UL listed. Finished products are individually labeled accordingly.

Sincerely,

Kenneth J. Kempf

Kenneth J. Kempf
President
Blue Patriot Fab
Ken@bluepatriotfab.com

MJ Anchor Coupling Dimensions

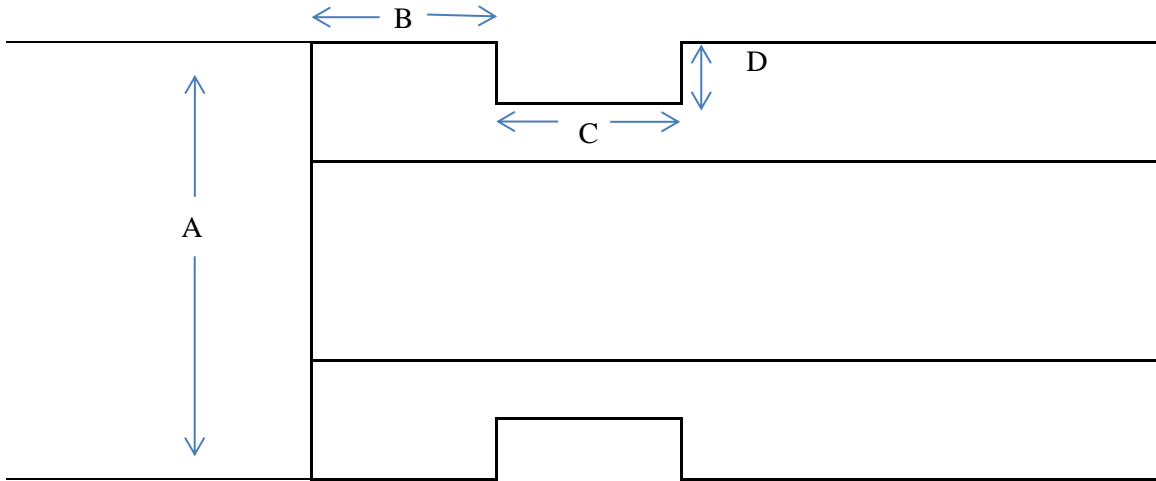

	A	B	C	D	Snap Ring
Size	(NOM. O.D.)	(CUTBACK)	(WIDTH)	(DEPTH)	WIDTH
Tolerance	(+ / -)	(+ / -)	(+ .015)	(+ / -)	(+ / -)
3"	4.02	2"	.250	.130	.2344
4"	4.86	2"	.250	.130	.2344
6"	6.96	2"	.250	.130	.2344
8"	9.11	2"	.250	.130	.2344
10"	11.16	2"	.250	.130	.2344
12"	13.26	2"	.250	.130	.2344
14"	15.35	2 1/2"	.375	.1875	.3595
16"	17.45	2 1/2"	.375	.1875	.3595
18"	19.55	2 1/2"	.375	.1875	.3595
20"	21.65	2 1/2"	.375	.1875	.3595
24"	25.85	2 1/2"	.375	.1875	.3595
30"	32.08	2 3/4"	.500	.250	.4844
36"	38.38	2 3/4"	.500	.250	.4844
42"	44.58	2 3/4"	.500	.250	.4844
48"	50.88	2 3/4"	.500	.250	.4844

- 1) Minimum class 53 ductile iron pipe specified in all sizes
- 2) Dimensions are manufactures standard, tolerances may vary.

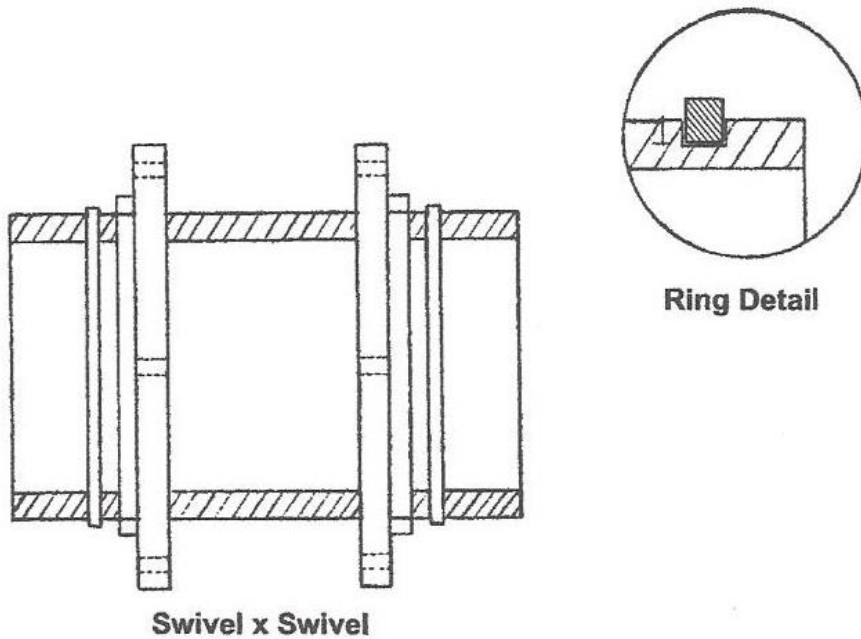

Notes:

Tolerance on length of pipe shall be 0.25”.

Above materials shall meet all applicable sections of A.N.S.I. A21.10, A21.15, A21.50, A21.51, B2.1, B16.1/ A.W.W.A. C110, C115, C150, C151, and all revisions thereto.

Anchor pipe shall be made of Ductile Iron Pipe Class 53.

Lining shall be in accordance with A.N.S.I. A21.4., AWWA C104

Mechanical Joint Gland A.N.S.I. / A.W.W.A. A21.10 / C110, A21.53 / C153.

Available in all sizes and lengths – as required.